



**K Y O T O
S M A R T
C I T Y
E X P O
2 0 2 4**

Regions and industries to create a sustainable and livable future

– Creating a “Meta-Comfort” smart society

Together Towards
the **Future**

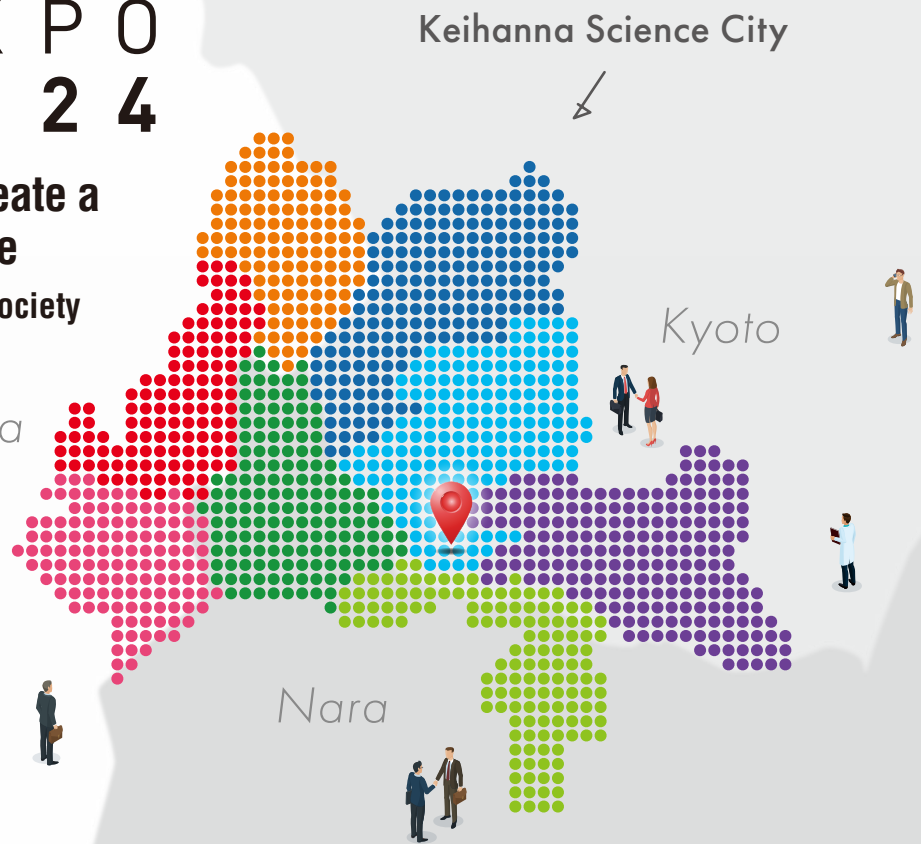

KYOTO SMART CITY EXPO 2024 · KYOTO FOODTECH EXPO 2024

Sponsorship and Exhibitions

Event dates

2024.10/3 Thu · 4 Fri

Venue **Keihanna Open Innovation Center@Kyoto (KICK)**

Seika/Nishi-Kizu area of Kyoto Prefecture

Organizer

THE ORGANIZING COMMITTEE OF KYOTO SMART CITY EXPO

Kyoto Prefecture, Kyoto City, Kyotanabe City, Kizugawa City, Seika Town, Barcelona City Council, Fira de Barcelona, Embassy of Spain Economic and Commercial Office Tokyo, Embassy of Denmark, Japan Spain Business Cooperation Committee, Kyoto Chamber of Commerce and Industry, Kyoto Industrial Association, Public Foundation of Kansai Research Institute, Kyoto Chiesangyo Sozonomori, Kyoto Industrial Support Organization 21, Advanced Scientific Technology & Management Research Institute of KYOTO, Kyoto Convention & Visitors Bureau, Internet Association Japan, Keihanna Interaction Plaza Incorporated

For further information and applications > <https://smartcity.kyoto/expo2024/en/>
[Deadline] Fri. July 26th, 2024 at 23:59



KYOTO SMART CITY EXPO



KYOTO SMART CITY EXPO

KYOTO FOODTECH EXPO 2024

"Find, Meet, Create" at the Kyoto Smart City Expo in Keihanna

Keihanna Science City, where more than 150 research, educational, and cultural facilities are concentrated, is a hub for open innovation, and works on smart city keywords such as AI, health/femtech, metaverse, foodtech, municipal DX, SDGs, etc. Keywords related to smart cities are brought together to build a new creative space.

Exhibitions and business seminars on the latest technologies and services related to smart cities on a domestic and international scale

Keihanna Expo Special Exhibition introduces **Keihanna's new gathering of knowledge** for innovations

BtoB and BtoG **business matching** to build alliances, from Keihanna

Startup pitch meetings and ideathons for open innovation

【Concurrent events】

「**KYOTO FOODTECH EXPO 2024**」The pursuit of traditional food culture and health functionality nurtured in Kyoto's history, combined with processing, distribution, and other technologies.

「**Keihanna Business Messe 2024**」Local companies offering world-class, one-of-a-kind technology and manufacturing will be exhibiting.

Outline

| | |
|--------------|--|
| Event Date | Thu. Oct. 3rd - Fri. Oct. 4th, 2024 |
| Event time | 10:00 ~ 17:00 |
| Venue | Keihanna Open Innovation Center@Kyoto (KICK) [Seika Nishi-Kizu area of Kyoto Prefecture] |
| Entrance fee | Free |
| Program | <div style="display: flex; flex-direction: column; gap: 10px;"> <div style="display: flex; align-items: center;"> <div style="background-color: #444; color: white; padding: 5px 10px; margin-right: 10px;">Exhibitions</div> <p>Smart city and food tech companies, international pavilions, Keihanna Expo 2025 special exhibition, etc.</p> </div> <div style="display: flex; align-items: center;"> <div style="background-color: #444; color: white; padding: 5px 10px; margin-right: 10px;">Speeches</div> <p>Symposium, Seminars, Start-up Pitch Contest, etc.</p> </div> <div style="display: flex; align-items: center;"> <div style="background-color: #444; color: white; padding: 5px 10px; margin-right: 10px;">Networking</div> <p>Reception, Exhibitors networking event, Booth tours, Roundtables, etc.</p> </div> </div> |

Attendees by category (for Kyoto Smart City Expo 2023)

Attendees (for both days) **12,500**
Exhibitors Companies / Organizations **112**
(including 20 Exhibitors in KYOTO FOODTECH EXPO 2023)
Sponsors **33**

The number of business achievement
 Business talks that will lead to a possible contract **42**
 Business talks that may lead to future sales **272**

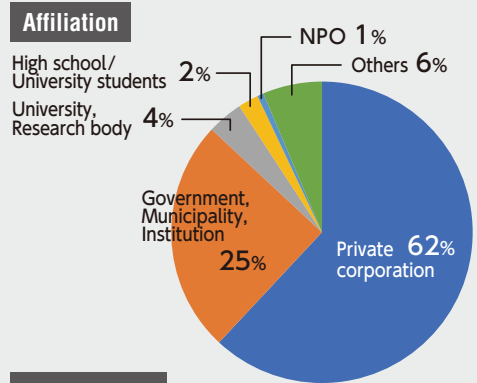

Visitors purpose

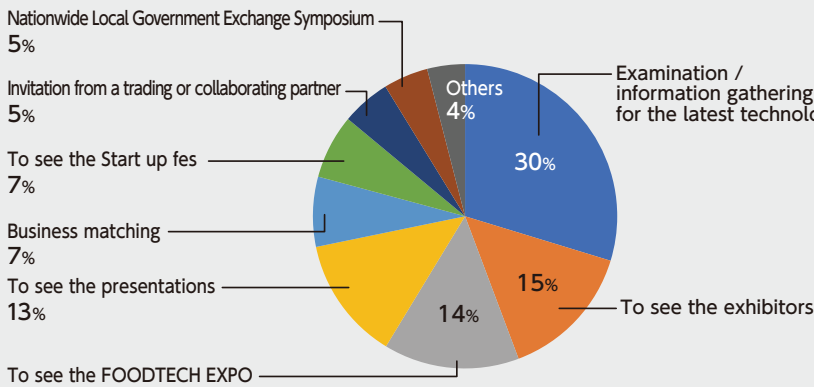

Job category

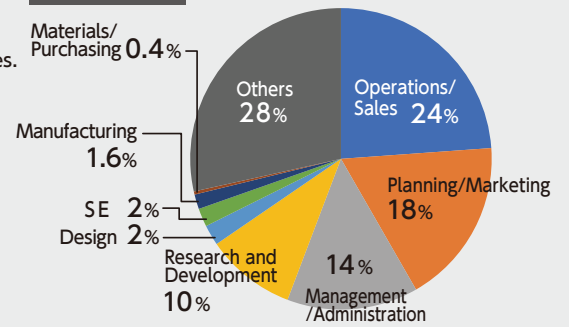

Sponsorship Plans

Global Premium Supporter

〈Sponsorship Fee〉 More than **3,300,000 JPY** (tax included)

Plan Details

- Publishing company name or logo (special size) on publicity materials
- Exhibition space at the event (4 regular booth spaces)
- Invitation to the reception (free invitation for up to 10 people)
- Priority assignment of reservations for the commemorative lecture, etc
- Access to supporter room (Global premium/platinum supporter lounge)
- Able to provide business seminars at the event
- Invitations to the Exhibitors networking event (up to 8 free invitations)

Platinum Supporter

〈Sponsorship Fee〉

3,000,000 JPY (tax included)

Plan Details

- Publishing company name or logo (extra large size) on publicity materials
- Exhibition space at the event (3 regular booth spaces)
- Invitation to the reception (free invitation for up to 10 people)
- Assignment of commemorative lecture time slots
- Access to supporter room (Global premium/platinum supporter lounge)
- Able to provide business seminars at the event
- Invitations to the Exhibitors networking event (up to 6 free invitations)

Gold Supporter

〈Sponsorship Fee〉

1,000,000 JPY (tax included)

Plan Details

- Publishing company name or logo (large size) on publicity materials
- Exhibition space at the event (2 regular booth spaces)
- Invitation to the reception (free invitation for up to 3 people)
- Assignment of seminar time slots
※Seminar time slots are limited and will be allocated on a first-come, first-served basis.
- Able to provide business seminars at the event
- Invitations to the Exhibitors networking event (up to 4 free invitations)

Silver Supporter

〈Sponsorship Fee〉

500,000 JPY (tax included)

Plan Details

- Publishing company name or logo (medium size) on publicity materials
- Exhibition space at the event (1 regular booth space)
- Invitation to the reception (free invitation for 1 person)
- Invitations to the Exhibitors networking event (up to 2 free invitations)

Co-creation Partners

We are looking for co-creation partners to join us in Keihanna Science City in conjunction with Kyoto Smart City Expo and Keihanna Expo 2025!

For further information about co-creation partners

Kansai Science City Promotion Division, Kyoto Prefecture

Tel: 075-414-5194 Mail: bunkaga@pref.kyoto.lg.jp

Please see page 07 about sponsorship applications

Exhibition Plans

Exhibitor Requirements

Corporations, organizations, etc. that operate business or projects related to smart cities, or groups/individuals related to such. The organizer may decline an exhibition if its content is deemed to not to match the purposes of the event.

Exhibition Fee

165,000 JPY (tax included) per booth space

Basic Booth/ Basic Facilities

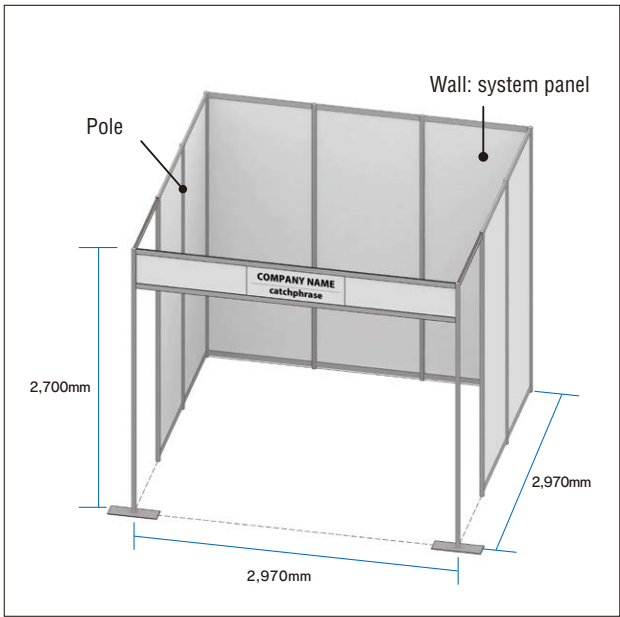

- Octanorm System Panel (Can be custom-decorated freely)
- Basic facilities involve system panels for partitioning side and rear walls installed by the organizer. The panels are system of plywood with white vinyl coating and cutting, nailing, drilling, mounting objects, or other panel alterations are not permitted.
- Exhibits on the wall like panels etc. must be attached with specialized chain (charge-free). *Double-sided tape may be also used.
- *Up to 10 velcro bands and 4 specialized chains per booth space. Extra will be charged.

1 Booth Space (about 3x3m) specifications

- Poles (Booth framework)
- System panel (booth wall) x7
- about 3m Parapet

Available charged booth options

Electrical set (2 LED arm spotlights, 1 outlet (2 plugs), electrical main line installation), desk, chair, display, punch carpet, etc.

Booth Space Layout

- [Regular booth space] Width - about 3m, Depth - about 3m, Height - 2.7m
- Can be set up in a row (up to 4 booth spaces), or in a block together (4 or 6 booth spaces)

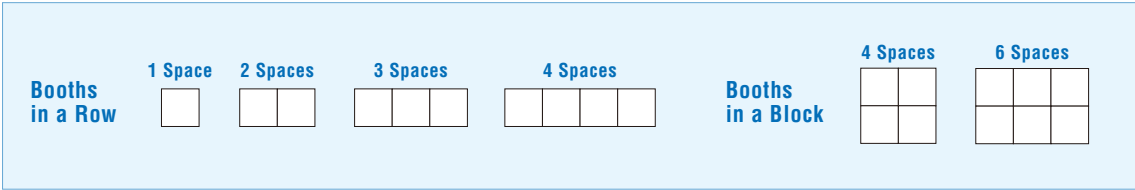

Booth Arrangement

The organizer will determine the location of booths that are considered advantageous for traffic flow and notify exhibitors on a first-come, first-served basis. However, please note that the organizer may not be able to meet your request due to the number of booths or the venue.

Panel Customization

- Exhibitors will be responsible for customization/decoration within the booth.
- Cutting, nailing, drilling, or other alterations to the basic booth itself including the panel boards, poles, beams, etc. are not permitted.
- Please notify the administrative office beforehand about exhibition items exceeding a height of 2.7m.
- Other details regarding regulations will be provided in the Exhibitor Manual distributed at the Exhibitor Briefing Session.

KYOTO FOODTECH EXPO 2024

The exhibition aims to integrate Kyoto's food culture, ingredients categorized as Kyoto vegetables, and cutting-edge technologies related to food. The exhibition will also provide a venue for encounters that will lead to the creation of foodtech, only possible in Kyoto thanks to its food processing technology, which has been nurtured through its long history, and cutting-edge technologies related to food from Japan and abroad.



Sponsorship Plans for KYOTO FOODTECH EXPO

| Premium plan | Standard plan | Basic plan |
|---|--|--|
| <p>〈Sponsorship Fee〉</p> <p>300,000 JPY (tax included)</p> <p>Plan Details</p> <ul style="list-style-type: none"> ■ Publishing company name or logo (special size) on publicity materials ■ 1 large booth space at the event (about 3x3m) ■ 30min presentation time ■ Invitation to the Exhibitors networking event (free invitation for up to 2 people) | <p>〈Sponsorship Fee〉</p> <p>150,000 JPY (tax included)</p> <p>Plan Details</p> <ul style="list-style-type: none"> ■ Publishing company name or logo (large size) on publicity materials ■ 1 standard booth space at the event (about 3x1.5m) ■ 15min presentation time ■ Invitation to the Exhibitors networking event (free invitation for up to 1 person) | <p>〈Sponsorship Fee〉</p> <p>50,000 JPY (tax included)</p> <p>Plan Details</p> <ul style="list-style-type: none"> ■ Publishing company name or logo (mid-size) on publicity materials |

Exhibit examples

- Food processing: Kyoto traditional foods, food culture, highly functional foods, alternative foods, new ingredients, cutting-edge processing technologies such as freezing, milling, 3D printers, etc.
- Agri-tech: smart agriculture technology, environmental load reduction, environmentally friendly agriculture technology, etc.

Booth and Facilities

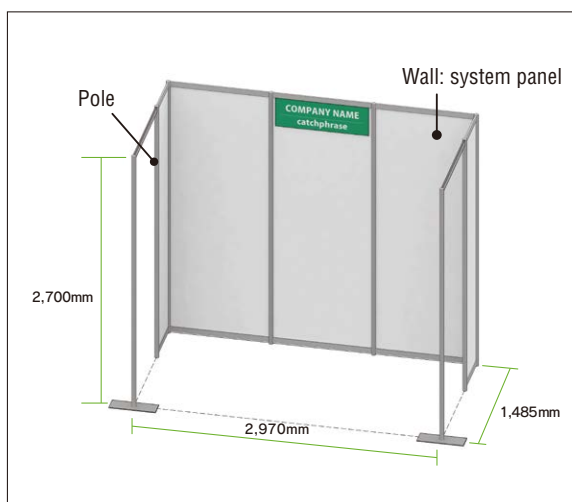

Exhibition Fee

Basic booth: about 3x1.5m **82,000 JPY (tax included)**

Large booth: about 3x3m **165,000 JPY (tax included)**

★Benefit: 15min presentation time at the seminar venue

Number of Available Booth Spaces:

30 (Including booth spaces provided for sponsors)

- Octanorm System Panel (Can be custom-decorated freely)
- Basic facilities involve system panels for partitioning side and rear walls installed by the organizer. The panels are system of plywood with white vinyl coating and cutting, nailing, drilling, mounting objects, or other panel alterations are not permitted.
- Exhibits on the wall like panels etc. must be attached with specialized chain (charge-free). *Double-sided tape may be also used.
- Up to 10 velcro bands and 4 specialized chains per booth space. Extra will be charged.

1 Basic Booth Space (about 3x1.5m) Layout

- 1 Company Name Board • System panels • Poles

Available charged booth options

Electrical set (2 LED arm spotlights, 1 outlet (2 plugs), electrical main line installation), desk, chair, display, punch carpet, etc.

Booth Arrangement

Booth allocation will be determined by the organizer and notified to exhibitors in consideration of the order of application, size of exhibits, and contents of exhibits.

Panel Customization

- Exhibitors will be responsible for customization/decoration within the booth.
- Cutting, nailing, drilling, or other alterations to the basic booth itself including the panel boards, poles, beams, etc. are not permitted.
- Please notify the administrative office beforehand about exhibition items exceeding a height of 2.7m.

(1) Cooking with fire is not allowed inside the venue. (2) The use of fire is permitted outside the venue in kitchen cars, etc., but prior application is required.

〔Idea〕Corporate version of Furusato Nozei (hometown tax) (Donation plan)

〈Donation amount〉

500,000 ~ JPY

■ How your donation will be used

Initiatives to solve issues and promote food-related industries in the prefecture by integrating Kyoto's food culture and food processing technologies, which have been cultivated over a long history, with cutting-edge food-related technologies.

■ What you get in return

In addition to having your company's name listed on the Kyoto Prefecture website, depending on the amount of your donation, you will receive a letter of appreciation at the venue on the day of the expo, and you will be able to display your company's products in a free space.

Application Procedure for Sponsors and Exhibitors

All applications should be submitted via the dedicated Website.

URL for sponsor/exhibitor applications ▶ <https://miceform.jp/ksc-expo2024/>



The screenshot shows the registration form with fields for Organization's name, Exhibitor's name, Address (with sub-fields for apartment, floor, etc., city, region, country, and post code), TEL, FAX, and Person in charge. A note indicates that pink boxes highlight required fields.

Application Procedure

All potential sponsors and exhibitors should register via the dedicated Website above.

▼

Applicants will receive an email confirming their registration.

*The Administrative Office is available to answer any inquiries related to exhibits.
*The Organizing Committee will send sponsors and exhibitors an invoice for relevant fees.
*If applicants do not receive a confirmation email after completing registration, it may indicate a system error. In such cases, please contact the Administrative Office.

Contact information

Kyoto Smart City Expo 2023 Administrative Secretariat (Sakura International Inc.)

E-mail: ksce2024@sakurain.co.jp

Tel: +81 50-5804-1338

Business hours: 10am-12pm, 1pm-5pm (not available on weekends and national holidays)

Booth locations will be offered on a first-come, first-served basis for sponsorship and exhibitor applications.

Basic Schedule For Exhibition

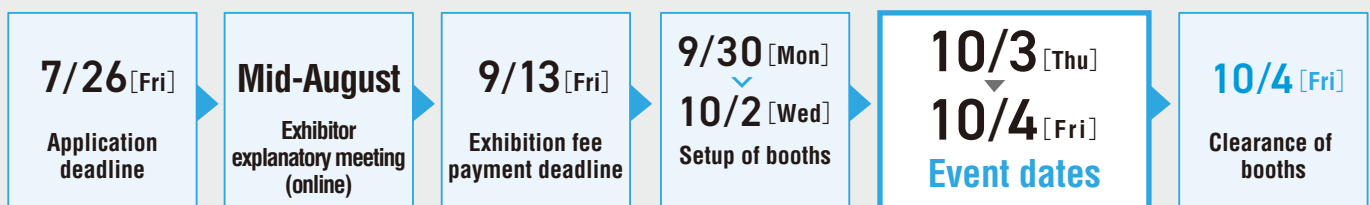

- The date and meeting access URL will be communicated later.
- Details about exhibitions will be explained in the "Exhibition Guidelines", which lists information about carrying in/out of exhibitions, fire/disaster prevention, construction, and other exhibition matters/regulations and report/application forms.

CAUTIONS FOR EXHIBITION

About Cancellation of the event Due to Unpredicted Reasons, etc.

- The organizer may alter the period of the event or cancel the event due to natural disasters or other unpredicted events or unavoidable reasons. In such cases, the organizer shall not be liable for any damages arising from such cancellation. Additionally, the exhibitors shall bear costs necessitated up to that point based on the number of booth spaces applied for.
- The period or opening time of the event could be altered due to unpredicted reasons. Exhibitors shall not cancel exhibitions or exhibition applications on the ground of such alterations. Additionally, the organizer shall not be liable for any damages occurring from such alterations.

Limitations and Prohibited Matters

- Booth spaces shall not be transferred, sublet, or exchanged.
- Exhibition items/decorations shall not be sold during the event for any reason whatsoever.
- Actions that cause large numbers of attendees to gather and congest the pathways around booths are prohibited.
- Exhibitors are not allowed to invite attendees, conduct surveys or lottery, distribute pamphlets or gifts, or conduct similar such actions outside their own booths.
- Please ensure that lighting, volume levels, and sound quality will not disturb other exhibitors.
- Audiovisual equipment may be used within the booth for the purposes of explanations and presentations, while audio speakers can not be installed to face outside of your booth. Please install speakers to face the inside of your booth.

Protection/Management of Exhibition Items

- The organizer shall be responsible for general maintenance/management of the venue.
- Exhibitors shall constantly put their staff at their own booths during preparation and exhibitions, and shall be responsible for the protection and maintenance of exhibition materials.
- The organizer shall not bear any responsibilities for incidents such as damage due to natural disasters or other unavoidable events, loss, fires, or theft. Accordingly, in protecting exhibition items, exhibitors are recommended to take measures such as covering insurance policies, etc.

Ensuring Safety

- Exhibitors shall take measures to prevent accidents during carrying in/out, construction/preparation, presentation, and all other aspects of the exhibition, as indicated in the Exhibitor manual.
- In the event of any accidents caused by an exhibitor's actions, such exhibitor(s) shall be responsible for resolving the matter.
- The cost of modifications to exhibition decorations for the purpose of ensuring safety based on the Fire Services Act or other laws/ ordinances shall be borne by the exhibitor.

Access Public transportations are convenient.



[From the Nearest Station]

From Kintetsu "Shin-Hosono" station (30 min. from Kyoto station by express train), take the Nara Kotsu Bus number 36 or 56 and alight at "Koehigashi-dori" stop.
On the Kintetsu Keihanna Line, alight at "Gakken Nara-tomigaoka" Station. Take the Nara Kotsu Bus number 56 and alight at "Koehigashi-dori" stop.
A free shuttle bus will be available from the nearest station on event days

Contact information

Kyoto Smart City Expo 2024 Administrative Secretariat (Sakura International Inc.)

E-Mail: E-Mail : ksce2024@sakurain.co.jp

Tel: +81 50-5804-1338

Business hours: 10am-12pm, 1pm-5pm (not available on weekends and national holidays)

<https://smartcity.kyoto/expo2024/en/>